

Industrial Center Distributed Energy Resource Site Assessment Report of C&F Packing Co.



Site Description

C&F Packing Co. is a meat packing (sausage) facility located at 515 Park Ave, Lake Villa, IL 60046, which is a suburb of Chicago (see Figure 1). Nicor is working with C&F to install a combined heat and power (CHP) system that will meet a portion of the electrical loads in the facility as well as use waste heat from the engine jacket water to meet thermal loads in the facility. The plant is a state-of-the-art meat packing facility that is nearing completion. About a third of the meat processing operation has been placed in operation at the end of first quarter 2002. Full operation is expected to commence in the second quarter of 2002.



Figure 1 – C&F Packing, Villa Park, IL

Electric Load

The bulk of the electrical load involves the processing and cold storage of processed meat and sausage. This state-of-the-art facility consists of a series of refrigerated processing rooms, refrigerated storage rooms, refrigerated transfer hallways, steam cooking chambers and refrigerated loading docks.

Refrigeration System

The refrigeration plant, shown schematically in Figure 2 and pictorially in Figures 3 & 4, consists of an ammonia liquid overfeed system providing two temperature levels.

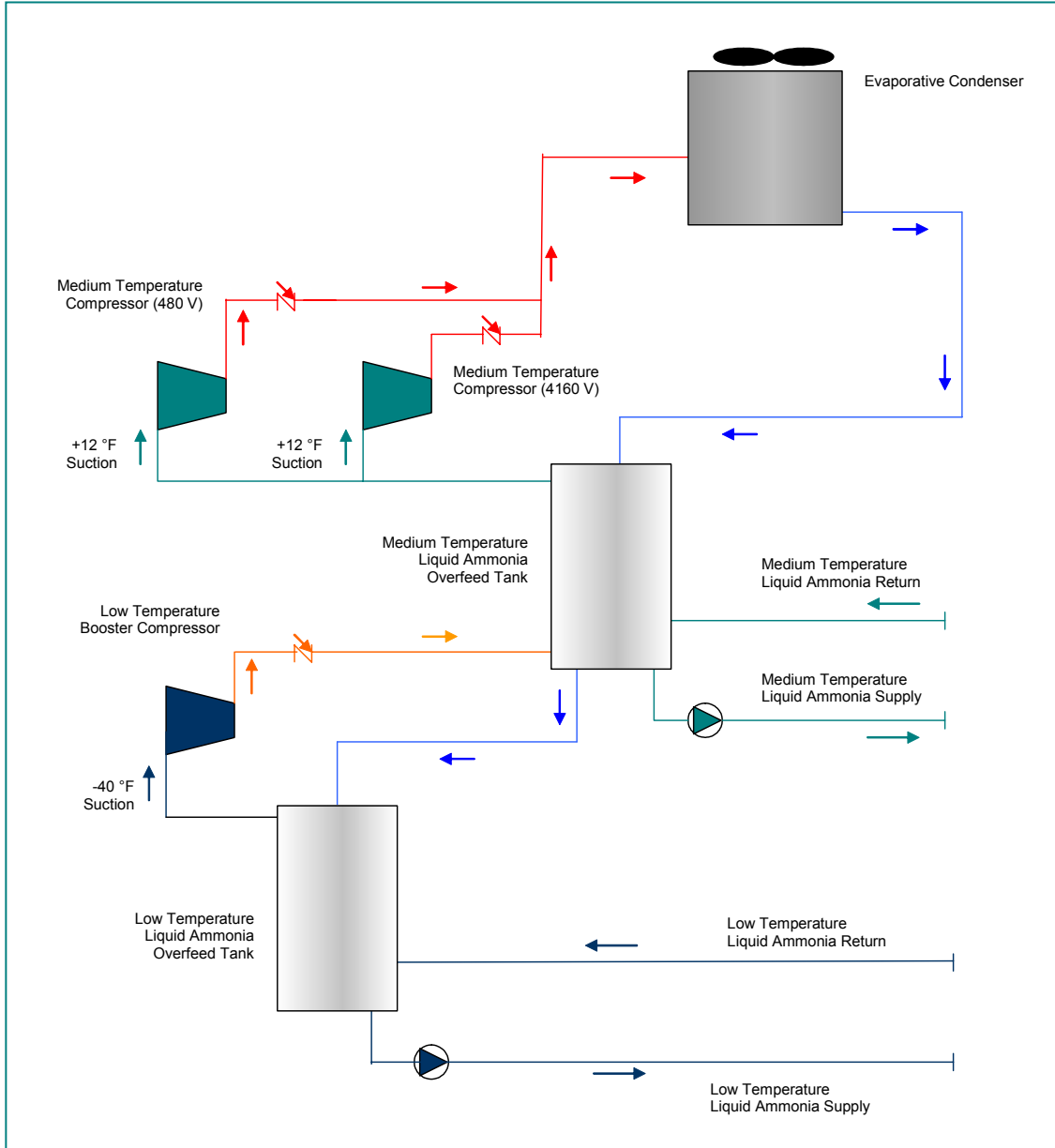

Figure 2 – Ammonia Liquid Overfeed System



Figure 3 – Low Temperature Booster Compressor

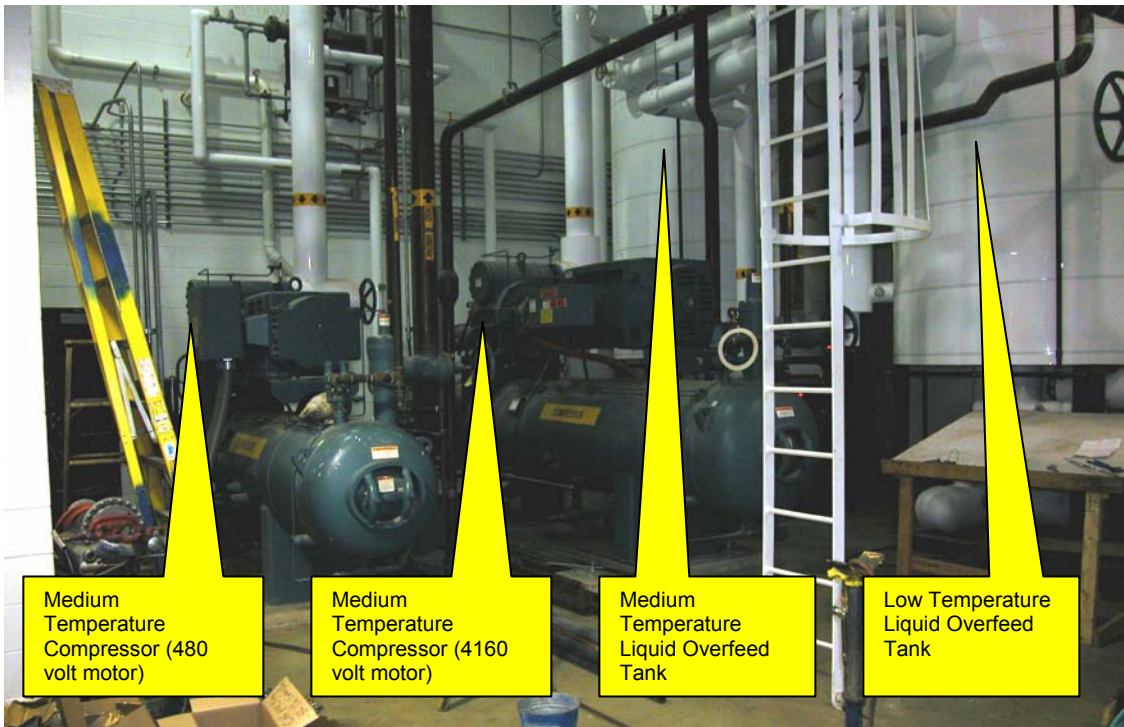

Figure 4 – Medium Temperature Compressors

One of the refrigeration compressors purchased by the customer operates directly on a 4160-volt service. As a result, the new control scheme calls for the 480-volt output from the two Waukesha engines to be stepped up through a transformer to 4160 volts (see Figure 5).

Electrical System

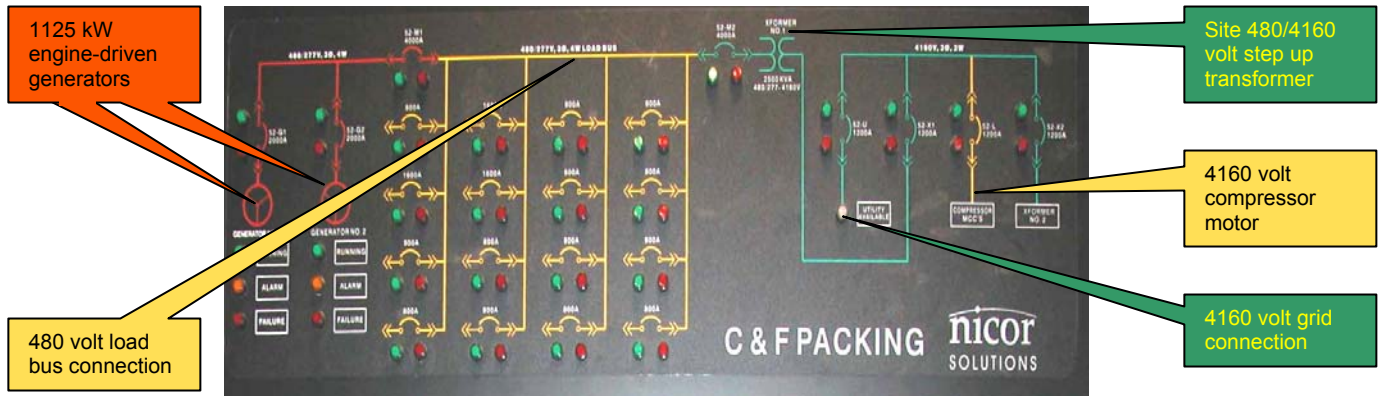

Figure 5 – Main Electrical Control Panel

Engine Generator System

Two Waukesha 1,125 kW engine generator units have been installed and have been placed in operation as of the end of the first quarter, 2002 (see Figure 6 and Table 1). The units are capable of providing 1,125 kW of continuous output and as much as 1,300 kW for short periods of time (i.e., when emergency power is required). The generator will feed 480 Volt, 3 phase, 4 wire loads in the facility electrical system. For emissions control, the engines have been equipped with Beard catalytic exhaust silencers. (see Appendix).

Heat Recovery System

Engine waste heat will be recovered via a Diamond Back™ double wall exchanger installed in series with the jacket water radiator on one engine (see Figure 7). The recovered heat will be used to preheat makeup water to the facility's boiler system.



Figure 6 – Generator Facility

Table 1 – Engine/Generator Performance

Generator System Model	Continuous kWe	Peak Shave kWe	Standby kWe	
VHP7100GSI/GSID	1,050	1,180	1,300	
Engine Model	Shaft Speed rpm	Compression Ratio	BHP	kWb
L7042GSI	800	8:1	985	735
L7042GSI	900	8:1	1,108	826
L7042GSI	1,000	8:1	1,232	919
L7042GSI	1,200	8:1	1,478	1,102

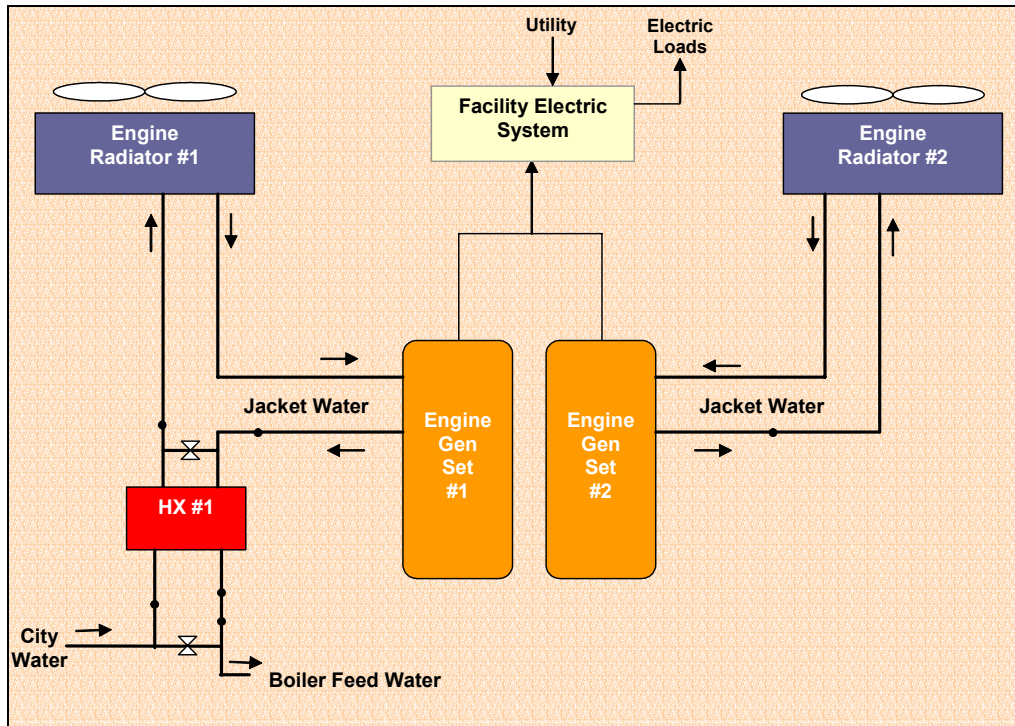

Figure 7 Schematic of CHP System at C&F

Diamond Back™ Double Wall Heat Exchanger

The heat exchanger is of a vented double wall construction. A unique diamond shape pattern provides multiple vented leak ports for positive indication of potential contamination. All Bell & Gossett Diamondback Double-Wall heat exchangers are UL Listed for use on potable water or other process systems where steam, water, and/or glycol/water solutions are the working fluids. A photo of the installed heat exchanger and cutaway are provided in Figures 8 and 9.

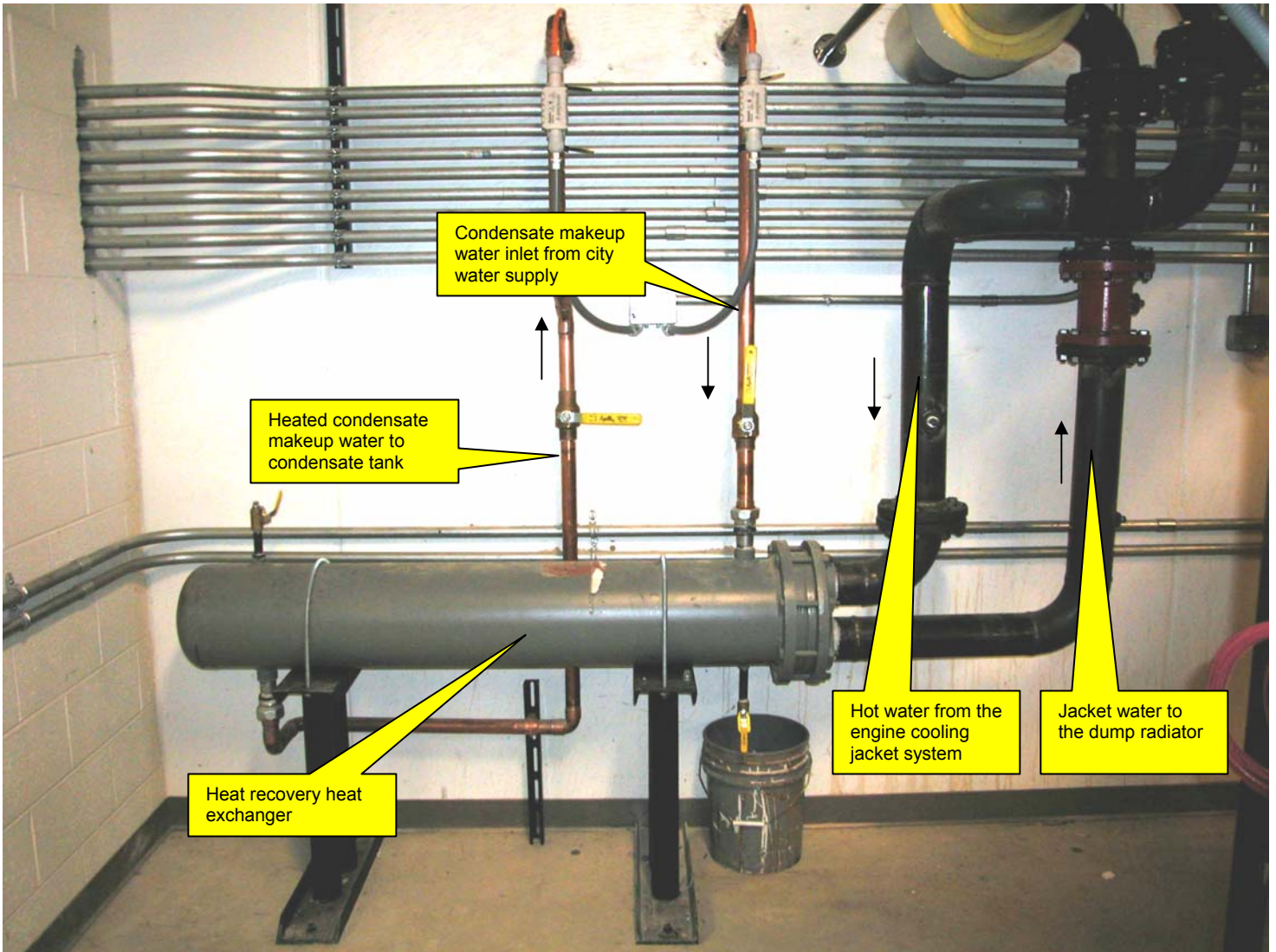

Figure 8 Heat Recovery System

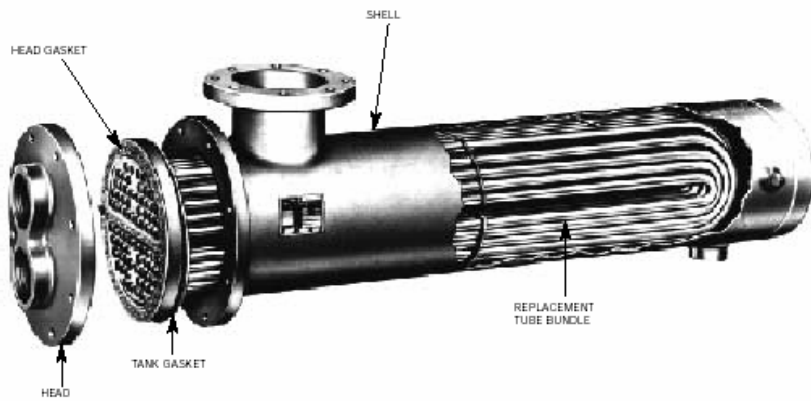

Figure 9 Double Wall Heat Exchanger

Boiler System:

The system includes two Burnham boilers each rated to provide 10,350 lb/h of 150 psi steam (see Figures 10 and 11). Steam is provided to process and space heating loads throughout the facility and well as to a hot water heat exchanger in the boiler room. Hot water at 150-160 F appears to primarily be used for wash-down operations throughout the facility. A separate gas-fired boiler supplies high pressure hot water (1,000 psi, 180 F) throughout the facility. Some processes at the facility consume steam directly, so feedwater requirements are expected to be higher since not all condensate will be returned to the boiler. Additional information on the boilers is provided in the appendix.

A significant amount of steam will be consumed in large direct contact food processing chambers. This once-through steam usage may provide future opportunities to substantially increase the heat recovery from the engine systems.



Figure 10 Boiler Room



Figure 11 Condensate System

Fuel Monitoring

The facility has a total gas meter and the engine/generators have a sub-meter. The sub-meter was specifically added for this project. The engine/generator sub-meter is a roots type and is equipped with temperature and pressure compensation (see Figure 12).



Figure 12: Natural Gas Sub-meter Installed for Data Acquisition Effort

Power Monitoring

The power output from the two generators (WENG) and the purchased power from the utility (WT) are the two most important data points. At this site the most cost effective way to measure power was to take data using the Modbus on the existing power meters. These time-resolved demand data will be used with the local utility tariffs to quantify the electric cost savings from on-site generation. Base case operating costs (i.e., without the engines) will be determined by combining the two power readings to determine total facility power consumption and then applying the utility tariff to that load. The process will then be repeated with the actual measured power consumption for the facility. The difference in these costs will be the electric utility cost savings realized by operating the engine. See appendix for a description of the power meter.

Site Operation

Plans are to operate the engine generator set between 9 am and 10 pm to take advantage of the current Commonwealth Edison rate structure. Heat is currently recovered from the jacket water of one of the engines for boiler feedwater preheating.

Site Economics

The onsite power equipment and installation economics are listed below and will be used to calculate simple payback based on the test results obtained.

Project Description: 2 – 1,125 kW generators

	Cost	Totals
EQUIPMENT		
Engine/Generators	\$ 851,000	
Heat Recovery Heat Exchanger	\$ 35,000 est	
Switchgear	\$ 450,000	
ComEd Interconnect	\$ 80,000	
Sub-Total:		\$ 1,416,000
 CONTRACTOR/LABOR		
Engine Installation (Mechanical)		
Engine Installation (Electrical)		
Engineering		
Start-up Training		
Project Management		
Construction Management		
Sub Total:		\$ 906,644
Total Expenses:		\$ 2,322,644

The project amount of \$2,322,644 represents the site cost-share for the assessment project.

Utility Rates

Natural Gas Rate: Nicor Gas Rate 74: <http://www.nicor.com/gas/gfyb/summary.htm>

Monthly Customer Charge	
More than 10,000 cfh	\$104.50
Distribution Charge	
First 150 therms at	\$0.1195
Next 4,850 therms at	\$0.0548
More than 5,000 therms at	\$0.0241
Administrative Charge	
Single account	\$24.00
Recording Device Charge	
Meter charge	\$12.00
Commodity Charge	
Gas Supply Cost (GC)	

Gas Supply Cost

Gas Supply Cost is the monthly average cost per therm of natural gas Nicor Gas purchases for its customers. The GC, as it's called, is filed with the Illinois Commerce Commission before it goes into effect. Nicor Gas charges our customers what we pay for the gas. The current Gas Supply Cost is: May 2002 is 38.00 cents per therm.

Electric Rate: ComEd Rate 6L http://www.ceco.com/graphics/09_Rate_6L.PDF

Rate 6L generally applies where maximum demand is consistently 1,000 kW or more and is a “Time of Day” rate.

Large General Service – Time of Day.

Monthly Customer Charge.

For customers with a Maximum Demand in any month during the most recent 12-month period, including the billing month, which is less than 10,000 kilowatts \$246.39

Demand Charge.

Charge per kilowatt for all kilowatts of Maximum Demand for the month:

Summer Months.

For the first 10,000 kilowatts \$16.41

For all over 10,000 kilowatts \$ 6.51

All Other Months.

For the first 10,000 kilowatts \$12.85

For all over 10,000 kilowatts \$ 5.03

For the purposes hereof, the Summer Months shall be the customer's first monthly billing period with an ending meter reading date on or after June 15 and the three succeeding monthly billing periods.

*** Energy Charge.**

Charge per kilowatt-hour for kilowatt-hours supplied in the month:

during Energy Peak Periods 5.022¢

during Energy Off-Peak Periods 2.123¢

Maximum Demand in any month shall be the average of the three highest 30-minute demands established during the Demand Peak Periods in such month, not more than one such demand to be selected from any one day.

Standby Electric Rate: ComEd Rate 18 http://www.ceco.com/graphics/12_Rate_18.PDF

Rate 18 generally applies if you operate your own electric generating facilities solely to meet your own on-site electric needs or if you use another form of energy in the operation of equipment and ComEd's electric service is used as a standby, auxiliary or reserve service.

Monthly Customer Charge.

For customers requiring only Standby Service the Monthly Customer Charge shall be:

For a Standby Capacity of:

greater than 10,000 kilowatts \$524.61

1,000 kilowatts to 10,000 kilowatts \$344.39

500 kilowatts to less than 1,000 kilowatts \$137.93

less than 500 kilowatts \$106.83

For customers requiring both Supplemental and Standby Service, the Monthly Customer Charge shall be \$98.00

Customer Charge shall be

*** Required Facilities Charge.**

The customer shall be billed a monthly Required Facilities Charge as follows:

Charge per kilowatt for kilowatts of Standby Capacity: \$ 2.99

*** Demand Charge.**

Charge per kilowatt for kilowatts of Maximum Demand for Standby Service for the monthly billing period:

For Standby Service for firm load that would otherwise be supplied by the Company under the otherwise applicable rate:

Summer Months:

For the first 10,000 kilowatts	\$15.16
For all over 10,000 kilowatts	\$ 6.29

All Other Months:

For the first 10,000 kilowatts	\$13.41
For all over 10,000 kilowatts	\$ 6.03

For Standby Service for interruptible load that would otherwise be supplied by the Company under Rider 26:

Summer Months:

For the first 10,000 kilowatts	\$0.70
For all over 10,000 kilowatts	\$0.14

All Other Months:

For the first 10,000 kilowatts	\$0.79
For all over 10,000 kilowatts	\$0.16

Expected Electric Rate (without generation): ComEd Rate 6L

Host Site Agreement

The host site agreement, which includes a memorandum of understanding between NICOR and C & F was executed on February 14, 2002.

Project Contacts

Dennis Olson, C&F co-owner

Russ Bartmess, Nicor, rbartme@nicor.com, 630.983.8676 ext 2342

Joe Parys, Nicor, jparys@nicor.com, 815.455.0271 ext 248

Michael Perry, Nicor, mperry@nicor.com, 630.983.8676 ext 2413

Clyde Schafer, Nicor, cschafer@nicor.com, 630.983.8676 ext

Rich Biljetina, Industrial Center, biljet@att.net, 202.251.8902

Rich Sweetser, Exergy Partners Corp., rsweetser@exergypartners.com, 703.707.0293

Hugh Henderson, CDH Energy, hugh@cdhenergy.com, 315.655.1063

Legal Notice

This report was prepared by EXERGY as an account of work cosponsored by UT-Battelle/DOE, the Industrial Center, and certain Industrial Center members. Neither UT-Battelle/DOE, Industrial Center, Industrial Center members, EXERGY Partners Corp., nor any person acting on their individual or collective behalf;

- a. Makes any warranty or representation, express or implied with respect to the accuracy, completeness, or usefulness of the information contained in this report, or that the use of any information, apparatus, method, or process disclosed in this report may not infringe privately-owned rights, or

- b. Assumes any liability with respect to the use of, or for damages resulting from the use of, any information, apparatus, method, or process disclosed in this report.

Appendix

Burnham Boilers:

Three-pass full wetback firetube type, constructed in accordance with requirements of the ASME Code, Section IV for 50 PSI and 125 PSI water or 15 PSI steam; Section I for higher-pressure steam. All units are registered with the National Board. Turbulator baffles are not used in tubes. Separate second and third pass rear tube sheets allow safe expansion and contraction. Water-backed rear turnaround promotes rapid internal circulation and reduces gas temperatures at the entrance to the second pass, reducing tube end stress. Easy opening hinged, insulated front flue doors with bolted closure provide full access to all tubes. A 16-inch diameter bolted rear access door with observation port provides access to the boiler furnace.

Rear tube access is provided by removing lightweight gasketed door(s) installed on the rear smoke-box. No elaborate seals are used. A manhole is furnished as standard on water and low-pressure steam boilers sizes 125 HP and larger; on high-pressure steam boilers sizes 70 HP and larger. Hand-hole washouts are provided for easy inspection and cleaning of waterside surfaces. All steam boilers provided with a dry pan to ensure dry steam. A feedwater diffuser is provided on high-pressure boilers. All water boilers are equipped with a dip tube at supply outlet and diffuser at return inlet. The round-flanged vertical smoke outlet is equipped with a locking quadrant damper. All boilers are provided with an enameled steel jacket installed over 2 inches of fiberglass insulation and lifting lugs. The boiler is mounted on a heavy-duty structural steel base with extended skid and burner platform for protection of the burner during shipment and rigging.



Engine Exhaust System



Beaird 14" MCCS-300 Catalytic Exhaust Silencer

For guaranteed reductions of the Oxides of Nitrogen (NO_x), Carbon Monoxide (CO), and Non-Methane Hydrocarbons (NMHC's) discharged in the exhaust stream.

All stainless steel construction (including flanges) for long life in high temperature and corrosive atmospheres.

Easy access to the catalyst bed without disconnecting the exhaust piping or compromising the integrity of the unit.

Standard size catalyst modules for easy mounting, handling, and cleaning by a single person.

Corrugated, high-temperature stainless steel honeycomb substrate with herringbone pattern mixed flow cells yields excellent performance.

Thin foil yields catalyst walls capable of high performance at low pressure loss.

State-of-the-art catalyst technology insures maximum catalyst durability.

Dual set point, digital display high temperature alarm/shutdown system standard on all units.

Model PM171 Power Meter



The PM171 Powermeter is "the square meter that fits a round hole"; made to fit both 4-inch round and 92 x 92 square DIN mountings. This makes it suitable for both new panels and retrofits. The PM171 measures up to 80 parameters and has 2 programmable relays. The PM171 comes in two models - the PM171P, which provides all basic power measurements plus harmonics, and the PM171E, which includes all PM171P functions and additionally offers energy measurements and data logging capabilities. The innovative front panel features a LED bar-graph indicating percent load. The PM171E also has an energy pulsing LED.

Voltage Inputs

690V AC Nominal Voltage Input

120V AC Nominal Voltage Input

Power Supply

90 - 264V AC

10 - 18V AC

18 - 36V AC

38-72V AC

Communication Protocols

Modbus & ASCII

DNP3.0 & ASCII

Current Inputs

1 Ampere

5 Ampere

Analog Output

No Analog Output